

A stand-alone module which pupils can adapt and incorporate into their own designs

## Alarm details

2 inputs—3 outputs

Use the PICAXE 08 Proto Board kit and a standard PICAXE-08 or 08M chip.

Additional component count:

- 1 x BC548 Transistor
- 2 x 10K Resistors
- 1 x red, 1 x green 3mm LED
- 1 x 6v Buzzer
- 1 x Tilt Switch
- 1 x Push to Make switch

Alarm programming can be adapted to your needs.

This example runs the following sequence:

- Alarm turned on by push to make switch
- All outputs on for 5 seconds
- Green LED on
- Alarm counts inputs from tilt switch
- When alarm counts fourth input, Buzzer sounds
- Buzzer pulses 40 times
- Buzzer off, red light on for 10 seconds
- Green light on for two seconds

Circuit resets

Note: This program is to show the range of possibilities, not to be a useable alarm.

PCB Wizard layout

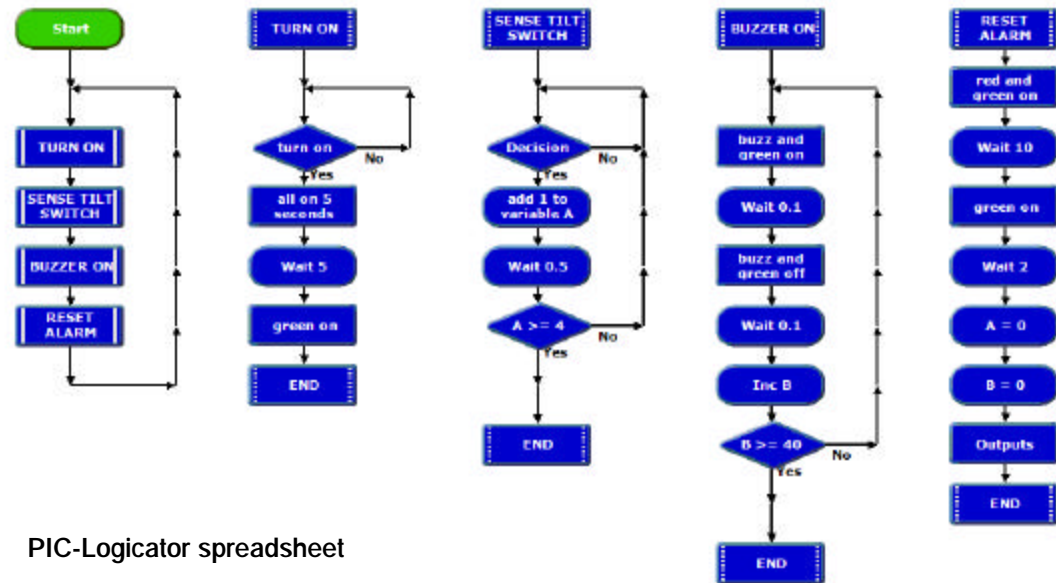
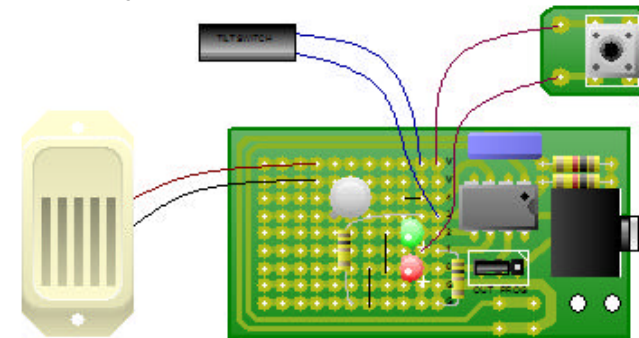

PIC-Logicator spreadsheet

A stand-alone module which pupils can adapt and incorporate into their own designs

```
let dirs = %00010101

main:
label_79:  gosub prc_TURN_ON      'Do Procedure
           gosub prc_SENSE_TILT_SWITCH  'Do Procedure
           gosub prc_BUZZER_ON  'Do Procedure
           gosub prc_RESET_ALARM    'Do Procedure
           goto label_79

prc_RESET_ALARM:
           high 0                Basic generated by PIC-Logicator
           high 2
           low 4
           pause 10000 'Wait command
           low 0
           high 2
           low 4
           pause 2000 'Wait command
           let b0 = 0 'Expression command
           let b1 = 0 'Expression command
           low 0
           low 2
           low 4
           return 'End

prc_BUZZER_ON:
label_46:  low 0
           high 2
           high 4
           pause 100 'Wait command
           low 0
           low 2
           low 4
           pause 100 'Wait command
           let b1 = b1 + 1 'Inc command
           if b1 >= 40 then label_52 'Compare command
           goto label_46
```

```
label_52:  return 'End

prc_SENSE_TILT_SWITCH:
label_31:  if pin3 = 1 then label_32 'Decision command
           goto label_31

label_32:  let b0 = b0 + 1 'Inc command
           pause 500 'Wait command
           if b0 >= 4 then label_53 'Compare command
           goto label_31

label_53:  return 'End

prc_TURN_ON:
label_23:  if pin1 = 1 then label_24 'Decision command
           goto label_23

label_24:  high 0
           high 2
           high 4
           pause 5000 'Wait command
           low 0
           high 2
           low 4
           return 'End
```

## Suggested uses for this alarm module

**KS3: Basis for pupils own alarm design.** Reduce cost by making pressure pads with copper sticky tape and pulsing Piezo transducer instead of buzzer

### KS4:

**Textiles**, incorporated into rucksack or CD holder

**Resistant Materials**, Garden security housed in camouflaged bird box

**Product Design**, Incorporated into children's room sensor device